

PROJECT TITLE: Electrical Lighting Project
LUMINAIRE CODE: FLD100
LUMINAIRE LOCATION: -

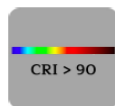

Distribution Curve of Meridian

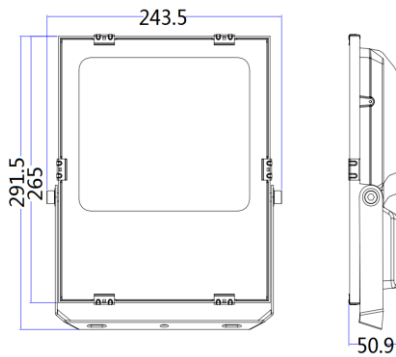
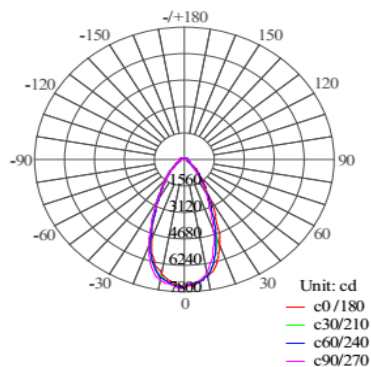

Luminaire Brand:
Stone

Model:
ST-TG10092B

Country of Origin:
China

Description:
100watt LED Surface Mounted LED Flood . NON-Dimmable

Protection Classification:
IP65

Compliance:
RoHs, CE

Material of Fitting:
Die Casted Aluminum, Tempered Glass

Finish:
Black

Lamp Type:
LED, OSRAM

Lamp Wattage:
100W

Input Voltage:
AC220~240V/ AC110V, 50/60Hz
NON-DIMMABLE

Luminous Flux:
11000 lumen

Efficacy:
110lm/W

Colour Temperature:
3000K / 6500K

Beam Angle:
150deg

CRI:
Ra>90

LED Life Span:
50,000 hrs

Dimension:
W=243.50mm, H=265mm,

Warranty:
2 years