

PROJECT TITLE: LED Spot Lighting - Long Distance
LUMINAIRE CODE: -
LUMINAIRE LOCATION: -

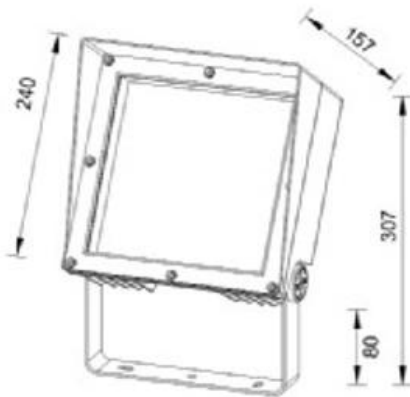
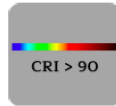

Luminaire Brand
Stone

Model
ST-MF240B

Country of Origin
China

Description:

48W LED Spot lighting fixture with Philips LED chip and Philips driver, energy-efficient, long lifespan, high lumen output, industrial warehouse factory gym lighting solution.

Protection Classification:
IP65

Compliance:
RoHs, CE

Material of Fitting:
Die Casted Aluminum

Finish:
White

Lamp Type:
LED, PHILIPS

Lamp Wattage:
48W

Input Voltage:
AC220~240V/ AC110V, 50/60Hz
No- DIMMABLE

Luminous Flux:
2600 lumen

Efficacy:
130lm/W

Colour Temperature:
3000K

Beam Angle:
90 / 120 Degree

CRI:
Ra>90

LED Life Span:
50,000 hrs / Reliable & Long Lifespan Solution

Dimension:
240X307X157mm

Warranty:
5 years